

FEATURES : HIGH REMOVAL RATE - LONG LIFE
APPLICATIONS : CAST IRON (GREY AND NODULAR) - SOFT STONES - FRP - OTHER
MACHINES : DEVELOPED FOR ANGLE GRINDERS
SAFETY : MAX PERIPHERAL SPEED 80 M/SEC (EN 13236)

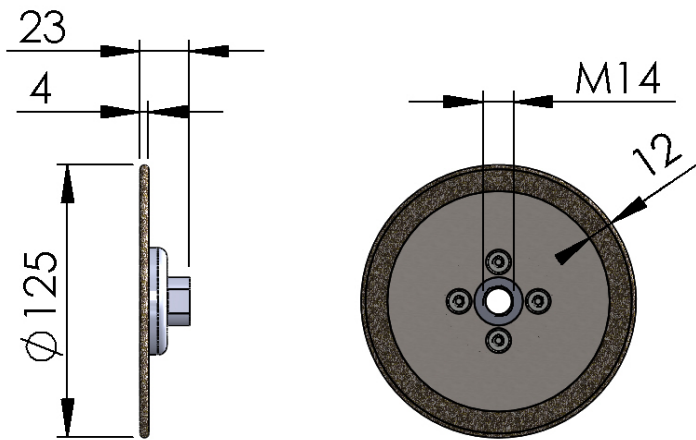
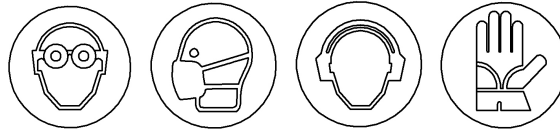

Ø 125 CUT & GRIND

F04868

MAX RPM 12.250

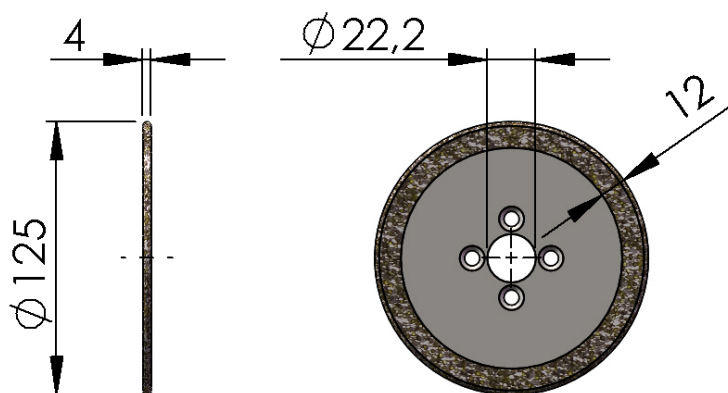

Ø 125 CUT & GRIND
(WITHOUT FLANGE)

F05372

MAX RPM 12.250

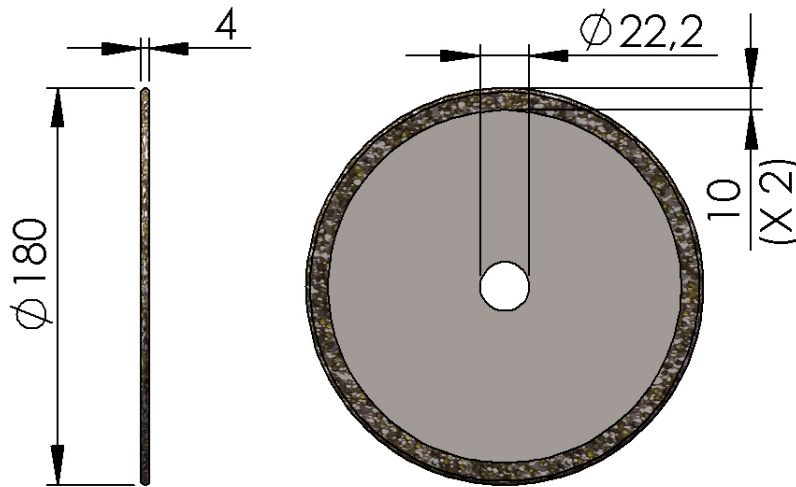

Ø 180 CUT
F05805
MAX RPM 8.500

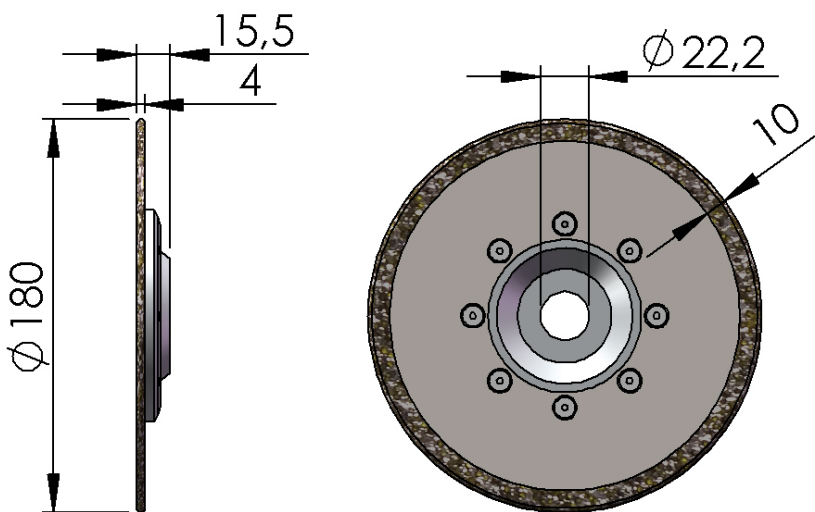

Ø 180 CUT & GRIND
F05804
MAX RPM 8.500

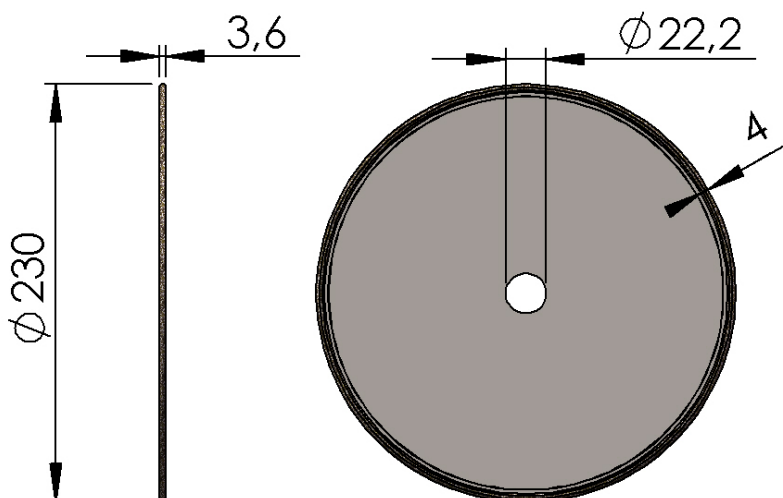

Ø 230 CUT
F00653
MAX RPM 6.650



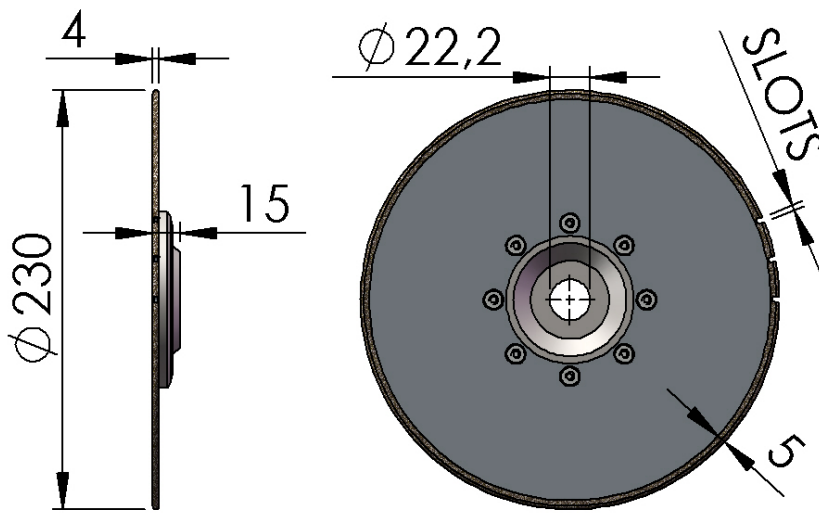

Ø 230 CUT
(FLANGE AND SLOTS)

F01001

MAX RPM 6.650

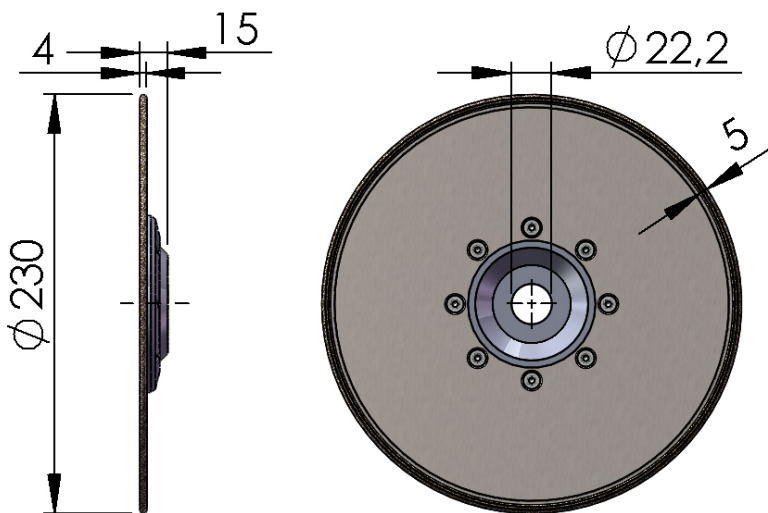

Ø 230 CUT
(FLANGE - NO SLOTS)

F06316

MAX RPM 6.650

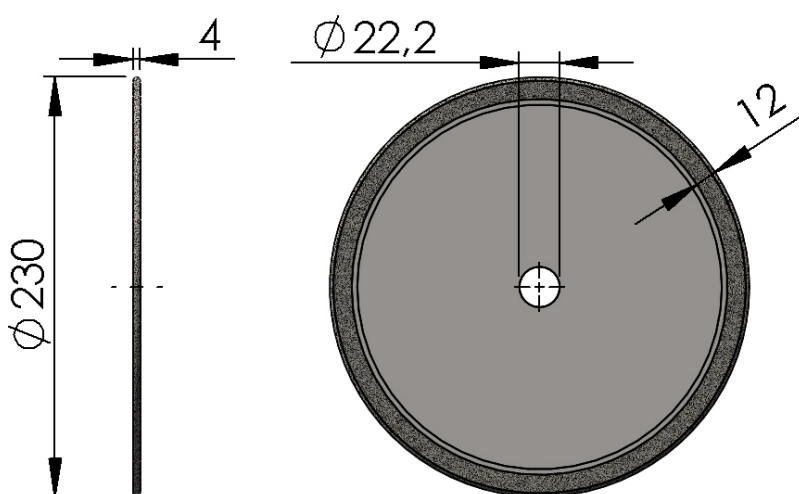

Ø 230 CUT

F06265

MAX RPM 6.650

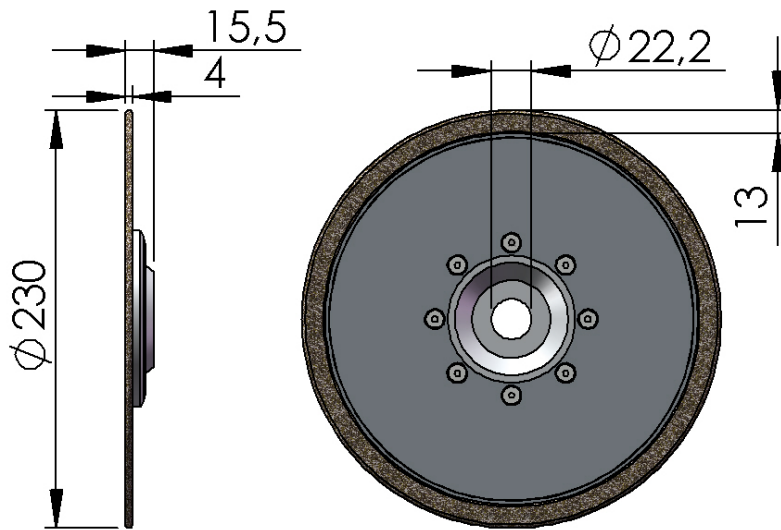

Ø 230 CUT & GRIND

F06251

MAX RPM 6.650

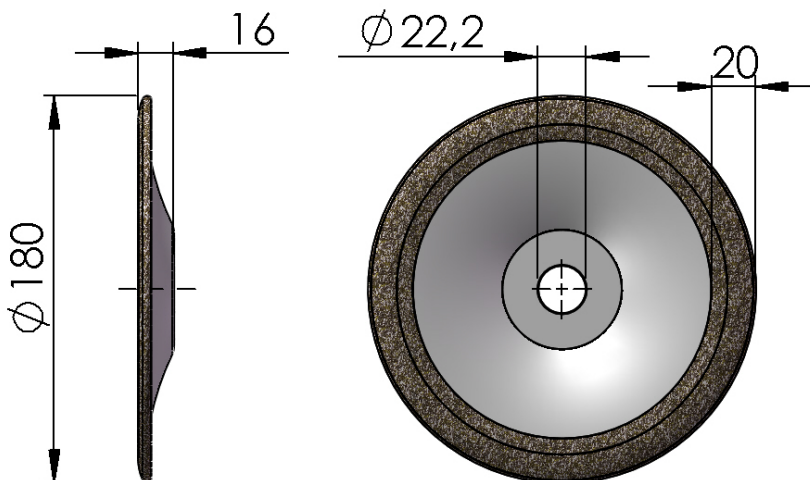

Ø 180 GRIND

F02450

MAX RPM 8.500